



BH(SDH)-0.66 II Current Transformer

1. Application

To be used in combination with measurement instruments: ammeters, watt-hour meters, measurement units, control relays, etc.



2. Technical data





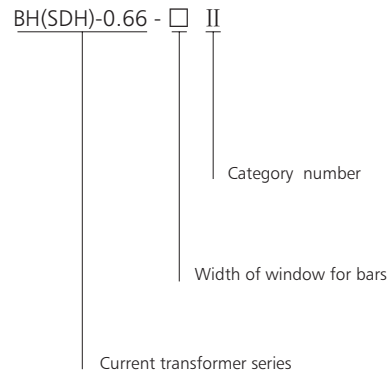



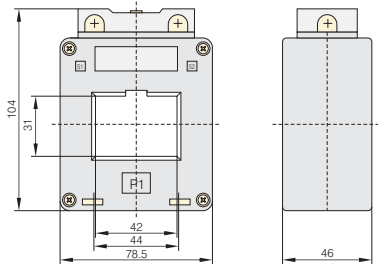

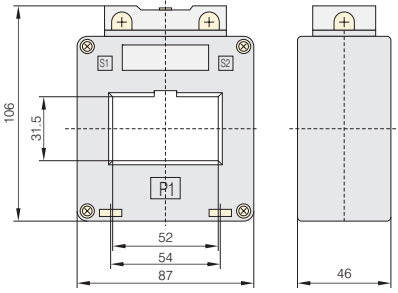

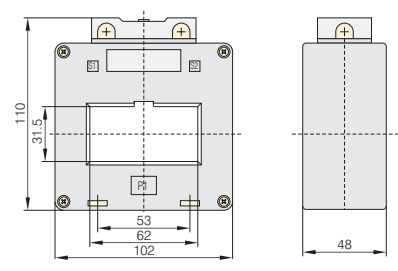

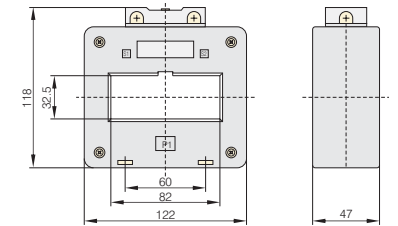

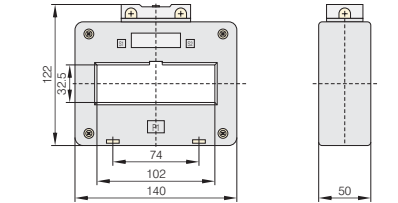

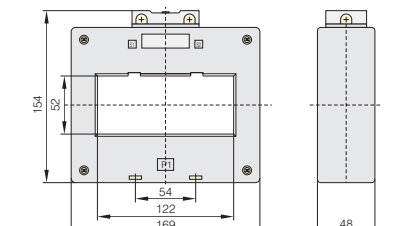

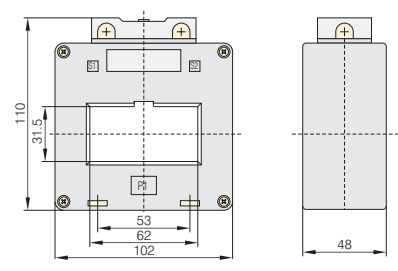

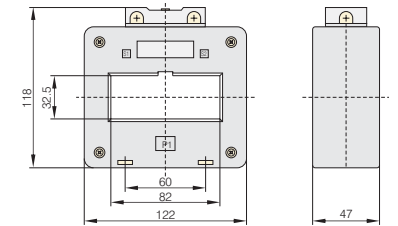

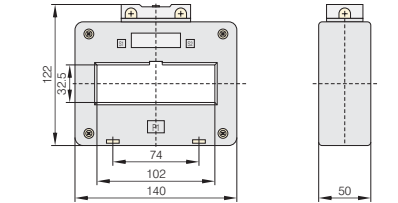

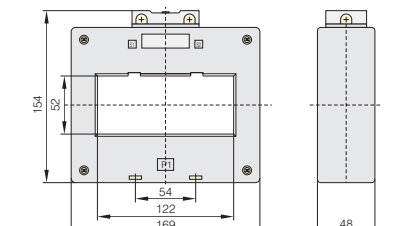

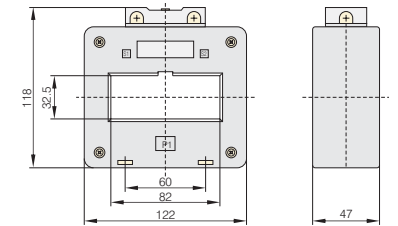
- 2.1 Secondary current I_{sn} : 5A
- 2.2 Rated voltage U_e : 660 V
- 2.3 Frequency: 50/60 Hz
- 2.4 Instrument security factor (FS): 10
- 2.5 Operating temperature: -5°C to +40°C, humidity <80%
- 2.6 Altitude: $\leq 1000m$
- 2.7 Standards: IEC 60044-1
- 2.8 Installation type: Busbar or plate fixing

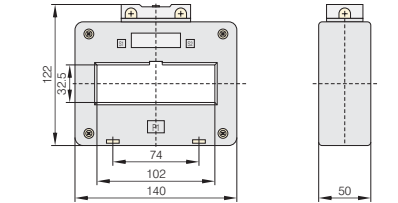
3. Type designation

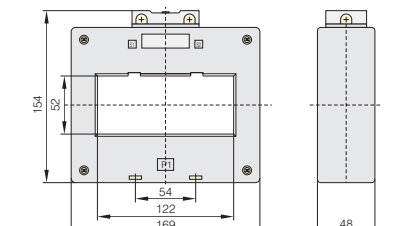

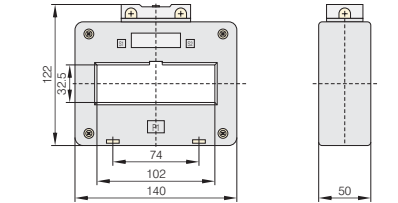
4. Technical data

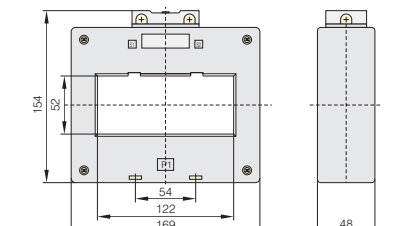
Model	Transformation ratio(I_{pn}/I_{sn}) (A)	Rated output(VA)				Number of turns through iron core	Overall and installing dimensions (mm)
		Accuracy class					
		1	0.5	0.5S	0.2		
 BH(SDH)-0.66 40 II	150/5	5	2.5			1	
	200/5	5	5			1	
	250/5	5	5			1	
	300/5	5	5			1	
	400/5	5	5			1	
	500/5	10	10	5	5	1	
	600/5	10	10	5	5	1	
750/5	10	10	10	10	1		

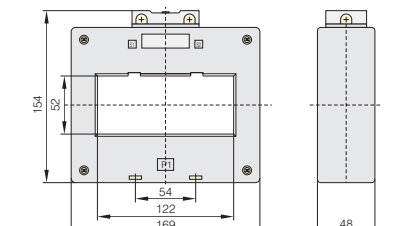
Model	Transformation ratio(I _p n/I _s n) (A)	Rated output(VA)				Number of turns through iron core	Overall and installing dimensions (mm)																																																																																																																																																						
		Accuracy class																																																																																																																																																											
		1	0.5	0.5S	0.2																																																																																																																																																								
 BH(SDH)-0.66 50 II	150/5	2.5				1																																																																																																																																																							
	200/5	5	5			1																																																																																																																																																							
	250/5	5	5			1																																																																																																																																																							
	300/5	5	5			1																																																																																																																																																							
	400/5	5	5			1																																																																																																																																																							
	500/5	10	10	5	5	1																																																																																																																																																							
	600/5	10	10	5	5	1																																																																																																																																																							
	750/5	10	10	10	10	1																																																																																																																																																							
	800/5	10	10	10	10	1																																																																																																																																																							
	1000/5	10	10	10	10	1																																																																																																																																																							
 BH(SDH)-0.66 60 II	1200/5	20	20	20	20	1		300/5	5	5			1	400/5	5	5			1	500/5	10	10	5	5	1	600/5	10	10	5	5	1	750/5	10	10	10	10	1	800/5	10	10	10	10	1	 BH(SDH)-0.66 80 II	1000/5	10	10	10	10	1		1200/5	20	20	20	20	1	1500/5	20	20	20	20	1	2000/5	20	20	20	20	1	600/5	10	10			1	750/5	10	10			1	 BH(SDH)-0.66 100 II	1000/5	10	10	10	10	1		1200/5	20	20	20	20	1	1500/5	20	20	20	20	1	2000/5	20	20	20	20	1	2500/5	40	40	40	40	1	 BH(SDH)-0.66 120 II	1000/5	10	10	10	10	1		1200/5	20	20	20	20	1	1500/5	20	20	20	20	1	2000/5	20	20	20	20	1	2500/5	40	40	40	40	1	3000/5	40	40	40	40	1	4000/5	40	40	40	40	1
	 BH(SDH)-0.66 60 II	1200/5	20	20	20	20		1																																																																																																																																																					
		300/5	5	5				1																																																																																																																																																					
		400/5	5	5				1																																																																																																																																																					
		500/5	10	10	5	5		1																																																																																																																																																					
		600/5	10	10	5	5		1																																																																																																																																																					
		750/5	10	10	10	10		1																																																																																																																																																					
800/5		10	10	10	10	1																																																																																																																																																							
 BH(SDH)-0.66 80 II	1000/5	10	10	10	10	1		1200/5	20	20	20	20	1	1500/5	20	20	20	20	1	2000/5	20	20	20	20	1	600/5	10	10			1	750/5	10	10			1	 BH(SDH)-0.66 100 II	1000/5	10	10	10	10	1		1200/5	20	20	20	20	1	1500/5	20	20	20	20	1	2000/5	20	20	20	20	1	2500/5	40	40	40	40	1	 BH(SDH)-0.66 120 II	1000/5	10	10	10	10	1		1200/5	20	20	20	20	1	1500/5	20	20	20	20	1	2000/5	20	20	20	20	1	2500/5	40	40	40	40	1	3000/5	40	40	40	40	1	4000/5	40	40	40	40	1																																												
	 BH(SDH)-0.66 80 II	1000/5	10	10	10	10		1																																																																																																																																																					
		1200/5	20	20	20	20		1																																																																																																																																																					
		1500/5	20	20	20	20		1																																																																																																																																																					
		2000/5	20	20	20	20		1																																																																																																																																																					
		600/5	10	10				1																																																																																																																																																					
750/5		10	10			1																																																																																																																																																							
 BH(SDH)-0.66 100 II	1000/5	10	10	10	10	1		1200/5	20	20	20	20	1	1500/5	20	20	20	20	1	2000/5	20	20	20	20	1	2500/5	40	40	40	40	1	 BH(SDH)-0.66 120 II	1000/5	10	10	10	10	1		1200/5	20	20	20	20	1	1500/5	20	20	20	20	1	2000/5	20	20	20	20	1	2500/5	40	40	40	40	1	3000/5	40	40	40	40	1	4000/5	40	40	40	40	1																																																																																		
	 BH(SDH)-0.66 100 II	1000/5	10	10	10	10		1																																																																																																																																																					
		1200/5	20	20	20	20		1																																																																																																																																																					
		1500/5	20	20	20	20		1																																																																																																																																																					
		2000/5	20	20	20	20		1																																																																																																																																																					
2500/5		40	40	40	40	1																																																																																																																																																							
 BH(SDH)-0.66 120 II	1000/5	10	10	10	10	1		1200/5	20	20	20	20	1	1500/5	20	20	20	20	1	2000/5	20	20	20	20	1	2500/5	40	40	40	40	1	3000/5	40	40	40	40	1	4000/5	40	40	40	40	1																																																																																																																		
	 BH(SDH)-0.66 120 II	1000/5	10	10	10	10		1																																																																																																																																																					
		1200/5	20	20	20	20		1																																																																																																																																																					
		1500/5	20	20	20	20		1																																																																																																																																																					
		2000/5	20	20	20	20		1																																																																																																																																																					
		2500/5	40	40	40	40		1																																																																																																																																																					
3000/5		40	40	40	40	1																																																																																																																																																							
4000/5	40	40	40	40	1																																																																																																																																																								